

# TCD 2012

For mobile machinery

66 - 155 kW | 91 - 210 hp at 2400 min<sup>-1</sup> | rpm

EU Stage IIIA / US EPA Tier 3

- Water-cooled 4 and 6-cylinder inline engines with turbocharging and charge air cooling
- The compact engine design and three PTO drive possibilities integrated into the gear drive reduce the installation costs and offer numerous application possibilities.
- The powerful DEUTZ Common-Rail (DCR®) injection system and the electronic engine control (EMR 3) with intelligent link to the drive management ensure optimum engine performance at low fuel consumption.

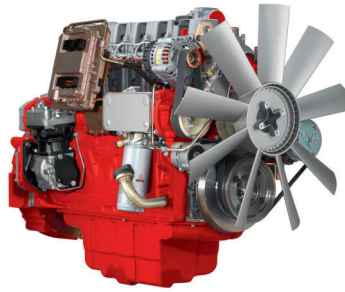

- The 4-cylinder is also available with a mechanical injection system in the power range up to 88 kW.
- Best cold starting properties even under extreme conditions.
- The 4-cylinder is also available with an optional mass compensation gear for low noise emissions and very smooth running so that expensive insulation measures can be omitted.
- Long oil change intervals and easy changing of the engine fluids reduce the running costs and increase the availability of the machinery.
- The robust engine design allows worldwide operation even with high sulphur fuels.

## Technical data

Engine type		TD 2012 L4 <sup>5)</sup>	TCD 2012 L4 <sup>5)</sup>	TCD 2012 L4	TCD 2012 L6
No. of cylinders		4	4	4	6
Bore/stroke	mm   in	101/126   4.0/5.0	101/126   4.0/5.0	101/126   4.0/5.0	101/126   4.0/5.0
Capacity	l   cu in	4.04   247	4.04   247	4.04   247	6.06   370
Compression ratio		18:1	18:1	18:1	18:1
Nominal speeds	min <sup>-1</sup>   rpm	2000 - 2300	2000 - 2400	2000 - 2400	2000 - 2400
Power output <sup>1)</sup>		TD 2012 L4 <sup>5)</sup>	TCD 2012 L4 <sup>5)</sup>	TCD 2012 L4	TCD 2012 L6
Power output as per ISO 14396	kW   hp	66   88.5	88   118	103   138	155   208
at speed	min <sup>-1</sup>   rpm	2300	2400	2400	2400
Max. torque	Nm   lb/ft	350   258	420   310	520   384	810 <sup>4)</sup>   597
at speed	min <sup>-1</sup>   rpm	1600	1600	1600	1600
Minimum idling speed	min <sup>-1</sup>   rpm	900	900	650	650
Specific fuel consumption <sup>2)</sup>	g/kWh   lb/hph	237   0.39	216   0.355	204   0.335	208   0.342
Weight as per DIN 70020 Part 7A <sup>3)</sup>	kg   lb	400   882	400   882	400   882	510   1124

1) Capacity data without deduction of fan capacity

2) Best full load consumption refers to diesel with a density of 0.835 kg/dm<sup>3</sup> at 15°C | 6.96 lb/US gallon at 60°F.

3) Without starter/dynamo, cooler and fluids but with flywheel and flywheel housing.

4) 850 Nm | 627 lb-ft with switched internal EGR (exhaust gas return)

5) Mechanical injection system

The data on this data sheet are for information purposes only and are not binding values. The data in the quotation is definitive.

## Torque curve

TCD 2012 L4 - 103 kW|138 hp

TCD 2012 L4 - 88 kW|118 hp

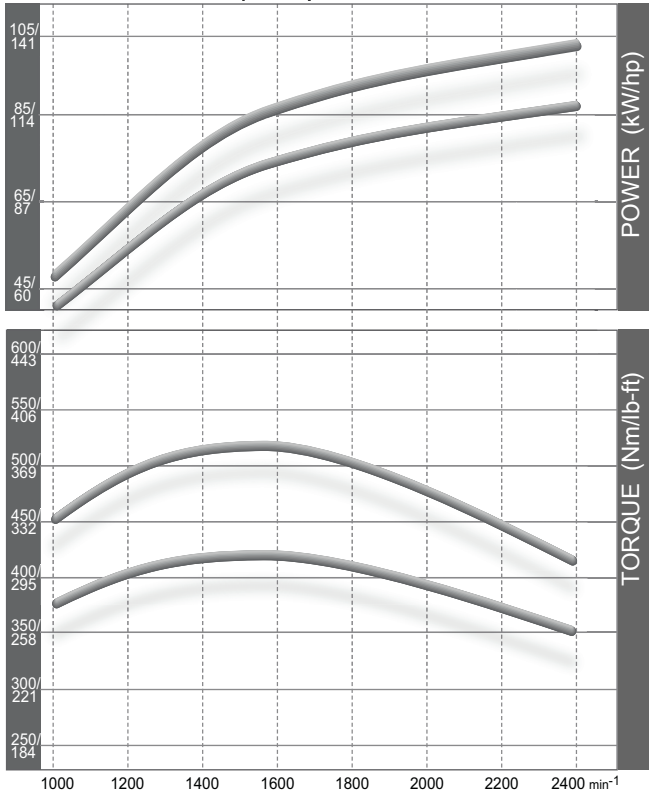

TCD 2012 L6 - 155 kW|208 hp

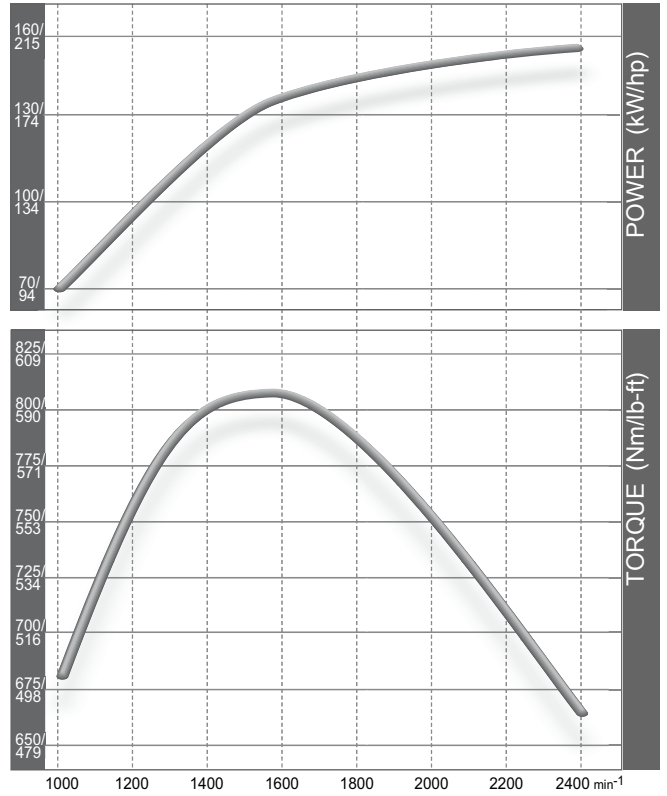

## Dimensions

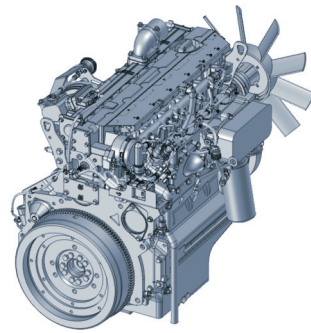
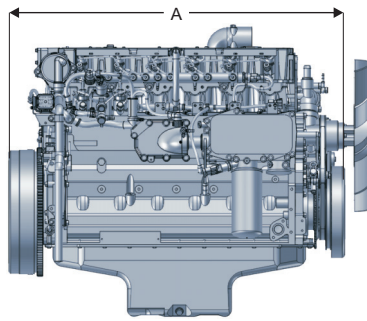
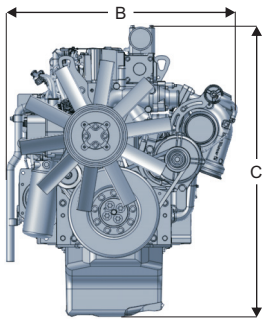

		A	B	C
TD 2012 L4 MECH.	mm   in	766 *   30.16	628   24.72	825   32.48
TCD 2012 L4 DCR®	mm   in	791 **   31.14	628   24.72	823   32.40
TCD 2012 L6 DCR®	mm   in	1018 **   40.08	659   25.94	893   35.16

\* V-belt drive

\*\* Poly-V belt drive

Note: The engine dimensions and weights vary depending on the scope of delivery.

Order No. 0031 2139 / 09 / 2011 / VC-CM

For more information please contact the DEUTZ AG Köln or the responsible sales partner.

